

HH-HMC-4



iHT HEATING

Table of contents

Introduction	4
Getting to know HH-HMC-4	4
Capabilities	4
Screens and icons	5
Unlocking the screen	6
Installation	7
What you need to know before installing the HH-HMC-4	7
Understanding power surges and surge suppression	7
Reducing electrical noise using filters	7
Electrical ratings	8
Bottom layout	9
Cover layout	10
Mounting the HH-HMC-4	11
Connecting equipment to the HH-HMC-4	11
Connecting heat mats	11
Connecting a probe for monitoring room temperature	13
Connecting an alarm system	13
Finishing the installation	14
Configuration	14
Configuring the main control functions	15
Setting the clock	15
Selecting the units of measure	15
Configuring alarm silencing	15
Configuring groups and equipment	16
Configuring groups	16
Configuring outputs	18
Configuring a room temperature probe	19
Settings	19
Programming group settings	20
Programming growth curves	20
Programming the group set point	21
Programming alarms	22
Using settings groups	24
Daily operation and maintenance	25
Monitoring your control	25
Widgets	26
Acknowledging and silencing alarms	26
Logs	27
Testing probes and equipment	28
Using manual override	28
Using screen lock security	29
Servicing and maintaining your HH-HMC-4	30
Restoring the factory defaults	30
Saving and restoring settings	31
Displaying version information	32
Updating the firmware	32
Replacement kits and optional accessories	33

Appendixes	35
Appendix A: Troubleshooting	35
Appendix B: Factory defaults	36
Appendix C: Worksheets	36
Installation worksheet	36
Configuration worksheets	37
Settings worksheets.....	38

Introduction

Getting to know HH-HMC-4

HH-HMC-4 is a powerful yet easy-to-use heat mat controller that can control up to four independent groups of mats. The HH-HMC-4 monitors the temperature in each group and then provides only the amount of heat required to maintain proper temperatures. By providing only the amount of heat required, your system is more energy efficient and you save money.

Capabilities

Programming options

Independent control groups	4
Automatic temperature control	✓ 70 to 125°F (21 to 51°C)
Manual override mode	✓
Growth curves	4
Settings groups	✓

Outputs

Variable AC stages	4
0 to 10 V DC signal outputs	4 With optional VDC-4
Alarm relay	✓

Temperature inputs

For heat mat control	4
For monitoring room temperature	1

Other

5-inch touchscreen	✓
Scrolling status screen	✓
Updatable firmware	✓ Via USB
Transferable settings	✓ Via USB
Diagnostics	✓
Hourly and daily logs	✓
NEMA 4X enclosure	✓ Corrosion-resistant, water-resistant, and fire-retardant
CSA approval	✓
2-year warranty	✓

Growth curves

A growth curve automatically adjusts temperature set points over time, up to a maximum of 365 days. There are seven steps in a growth curve; each step has a start day and a temperature. The HH-HMC-4 calculates the set points for each day between the steps and then adjusts them each day at midnight.

Easy to program, manage, and monitor

The touchscreen display allows you to easily configure, program, and check the status of your mats. From the status screen, you can easily access configuration, settings, and more. Every powerful feature is never more than a few taps away. This makes the HH-HMC-4 one of the easiest-to-use and user-friendly controls.

Security and peace of mind

When screen lock security is enabled, users can view the status screen but must enter the PIN before they can access any of the control’s functions.

The HH-HMC-4 is compatible with most alarm systems. You can connect the control to an alarm siren or other external alarm system. Customizable alarm settings allow you to choose which alarm conditions you want to be notified about.

Screens and icons

The Status screen is the “home” screen. Here you can find all basic information at a quick glance. The Status screen displays information about each heat mat and probe. The HH-HMC-4 automatically scrolls through each screen. Below are two examples.

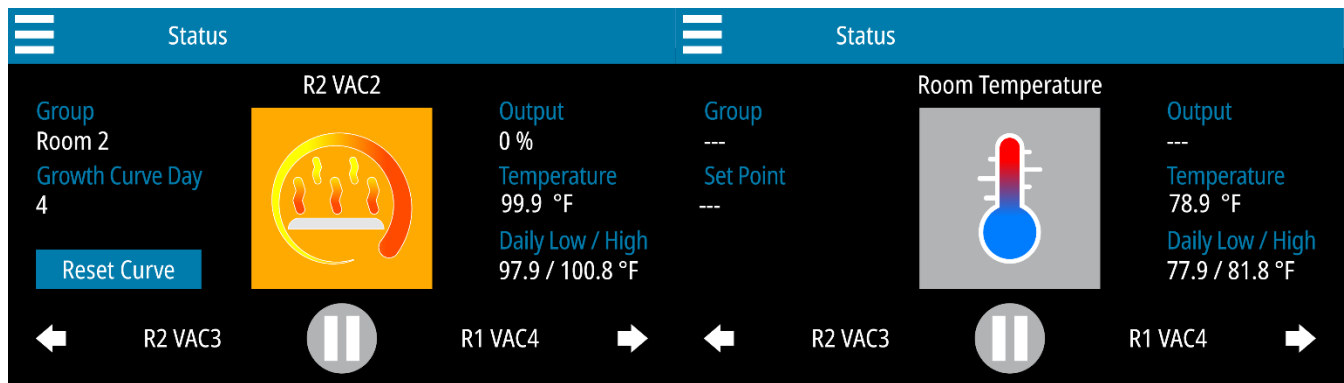



For more information about the status screen, read **Monitoring your control** on page 25.

Icons



-  **HOME**
Go to the status screen.

 **MENU**
Go to Manual Override, Settings, Configuration, Administration, Screen Lock, and About Menus.

 **BACK**
Go to the previous screen.

 **UP/DOWN**
Increase / decrease values.

 **LEFT / RIGHT**
Move / scroll through groups, equipment, or probes.

 **UNLOCK**
Enter the PIN to unlock the screen.
-  **SAVE**
Save changes.

 **CANCEL**
Discard changes and return to the previous screen.

 **PLAY**
Play / resume the status screen.

 **PAUSE**
Pause the status screen.

 **ALARM**
View the active alarm condition.

Menu

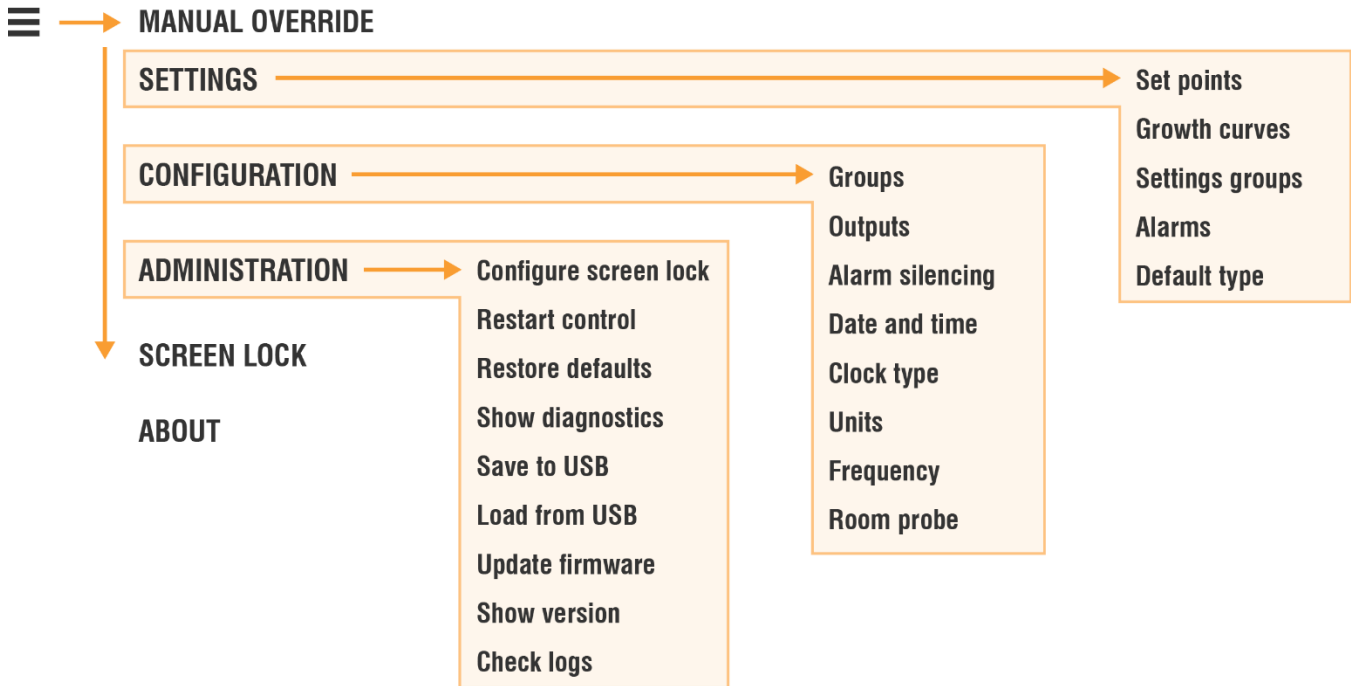

If you leave the control in a menu or screen other than Status, the control returns to the Status screen after five minutes without any key presses.

Unlocking the screen

Screen lock security is a feature you can use to control who makes changes to the control’s settings. The default setting for screen lock is *not enabled*.

When screen lock is enabled, users must enter the PIN before they can access the any of the control’s functions except the home screen. For more information, read **Using screen lock security** on page 29.

To unlock the screen

1. Press the **Lock** [] and then enter the four-digit PIN.
2. Press **Unlock Screen**.

Installation

What you need to know before installing the HH-HMC-4

1. Read the **Control Fundamentals** guide that came in the box with your control.
2. Read **Understanding power surges and surge suppression** below.



-
- ◇ If you do not install external surge suppression devices, you risk damage to the electronics inside the HH-HMC-4, which may cause the HH-HMC-4 to fail.
 - ◇ Because it is not possible to **completely** protect this product internally from the effects of power surges and other transients, we **highly recommend** that you install external surge suppression devices. For specific recommendations, see your electrical contractor.
 - ◇ If you do not take these precautions, you acknowledge your willingness to accept the risk of loss or injury.
-

3. List all the equipment you want to control on the **Installation worksheet** (starting on page 36). Install the equipment and make your electrical connections according to the sheet.
4. Use the installation worksheets to complete the **Configuration worksheets** (starting on page 37). List the equipment that is connected to each of the terminals and how you want it configured.

Understanding power surges and surge suppression

Power surges can be caused by external influences (influences outside the barn; for example, lightning or utility distribution problems) or they can be caused internally (inside the barn; for example, starting and stopping inductive loads such as motors).

One of the most common causes of power surges is lightning. When lightning strikes the ground, it produces an enormously powerful electromagnetic field. This field affects nearby power lines, which transmit a surge to any device connected to it, such as lights, computers, or environmental controls like the HH-HMC-4. Lightning does not have to strike a power line to transmit a surge.

Surge suppression devices offer some protection from power surges. Because it is not possible to internally protect this product completely from the effects of power surges and other transients, IHT Heating **highly recommend** that you install external surge suppression devices. For specific recommendations, see your electrical contractor. If you do not take these precautions, you acknowledge your willingness to accept the risk of loss or injury.

Reducing electrical noise using filters

Electrical noise is caused by high voltage transients created when inductive loads, such as power contactors, are switched on or off. The strength of the transients can be over 1000 volts and can vary with the type of equipment and wiring, as well as several other factors.

Visible symptoms of electrical noise include erratic control operation, cycling inlets, communication problems, and more. However, the **effects of electrical noise are not always visible**. Over time, electrical noise can cause electronic circuits, relay contacts, and power contactors to deteriorate.

Electrical ratings

Input power	120/230 VAC, 50/60 Hz
Control fuse [F5]	1 A, 250 VAC fast-acting glass
Variable AC stages	10 A at 120/230 VAC, general-purpose (resistive) 1200 W at 120 VAC; 2300 W at 230 VAC
Fuses [4: F1 to F4]	15 A, 250 VAC ABC-type ceramic
Alarm relay	0.4 A at 125 VAC; 2 A at 30 VDC, resistive load 0.2 A at 125 VAC; 1 A at 30 VDC, inductive load

Bottom layout

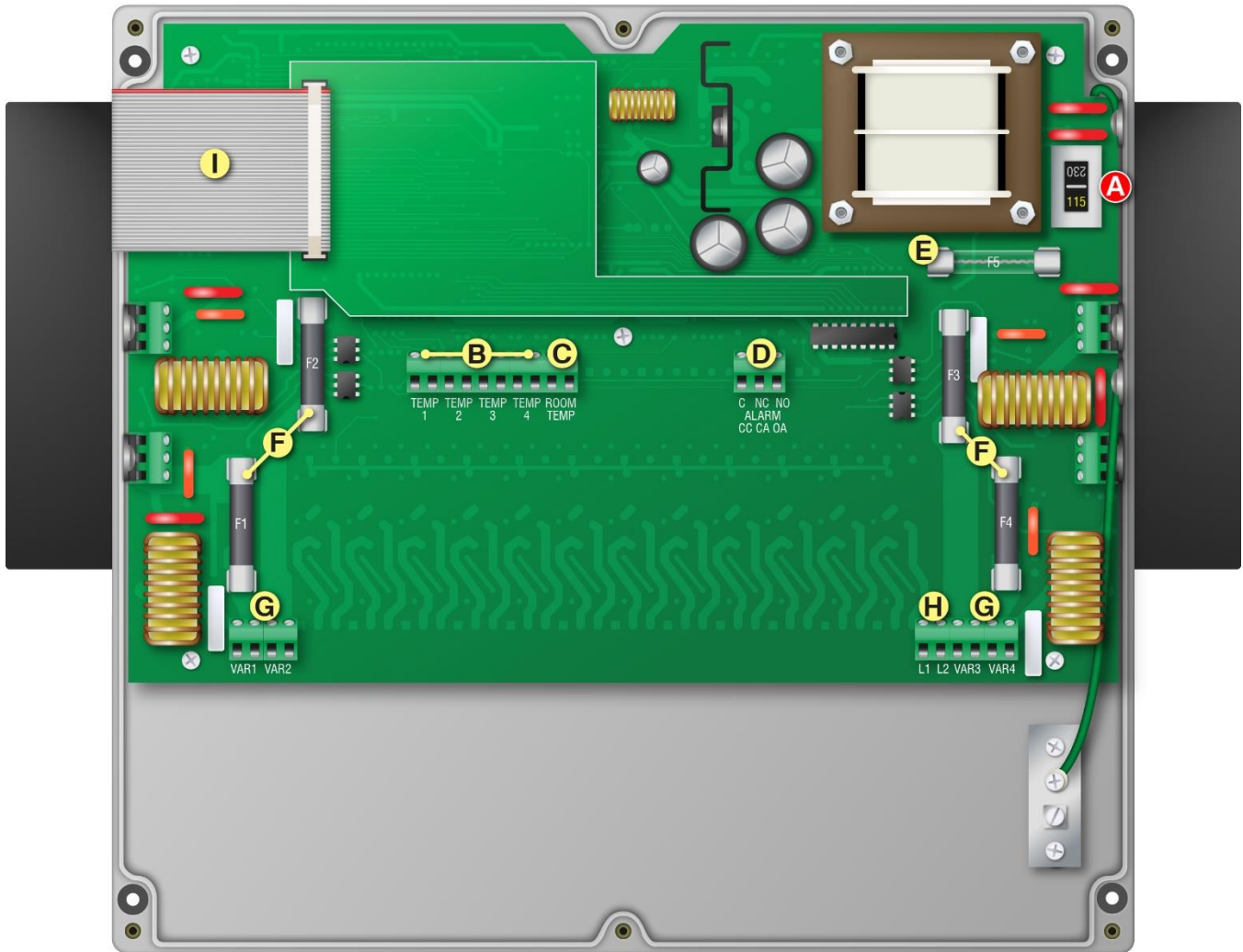

- (A) **Voltage switch:** ⚠ Set the switch to the correct line voltage.
- (B) **Temperature [TEMP1 to TEMP4]:** Connect the temperature probes for the heat mats.
- (C) **Room temperature [ROOM TEMP]:** Connect a Phason 3K Series temperature probe for monitoring room temperatures.
- (D) **Alarm relay:** Connect an external alarm system or siren.
- (E) **Control fuse:** Main control fuse
- (F) **Variable stage fuses [F1 to F4]:** Fuses for variable stages: F1 for VAR1, F2 for VAR2, and so on.
- (G) **Variable stages [VAR1 to VAR4]:** Connect variable speed fans or heating equipment.
- (H) **Incoming power:** Connect the incoming power from the panel.
- (I) **Display cable:** Disconnect the cable during installation. Reconnect it when done.

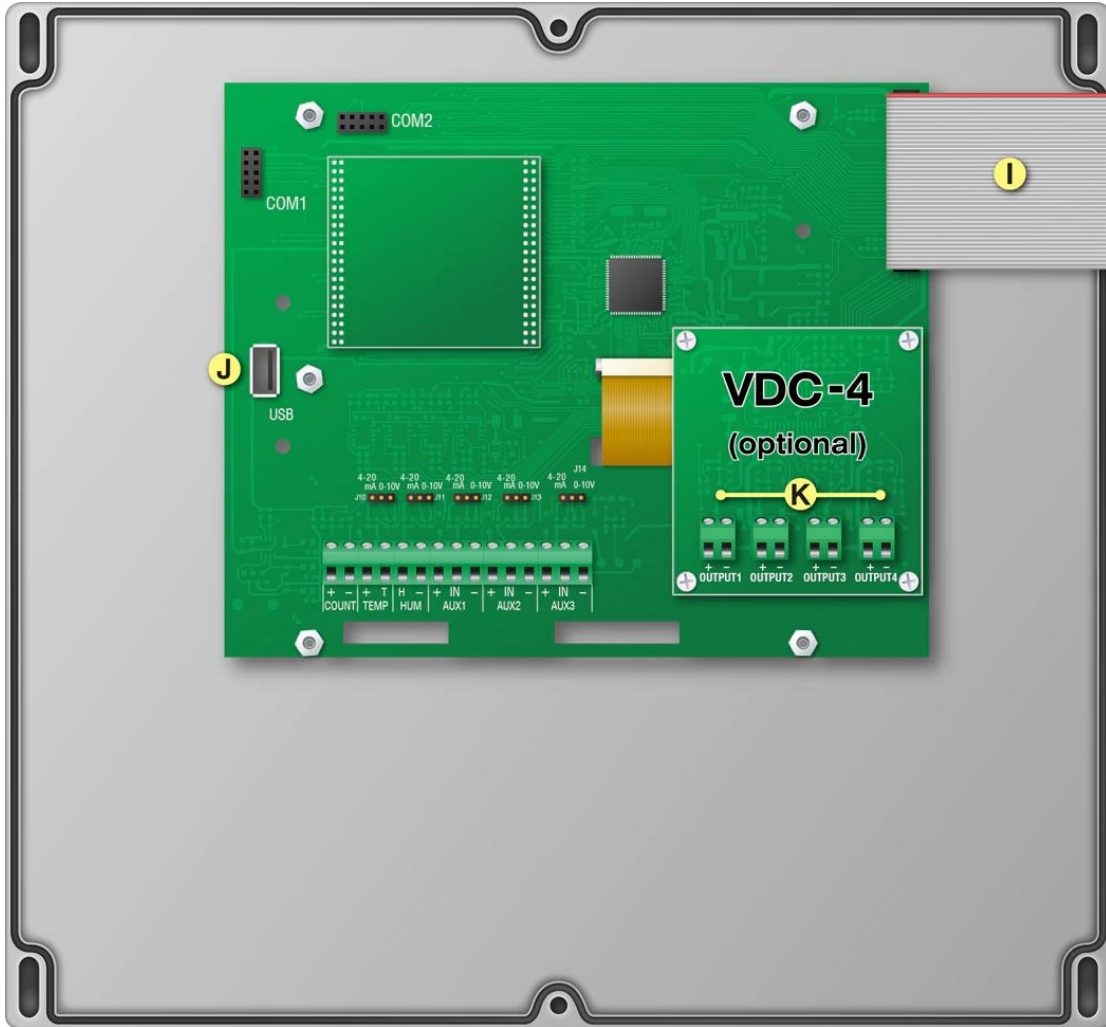
Cover layout

(I) **Display cable:** Disconnect the cable during installation. Reconnect it when done.

(J) **USB:** Connect a USB drive when saving / loading settings or upgrading.

(K) **VDC-4 [OUTPUT1 to OUTPUT4]:** Connect Expansion Boxes here.

Mounting the HH-HMC-4

1. Remove the screws from the front cover and then open it.
2. Mount the enclosure to a wall using the four screws provided with the control. Insert the screws into the large holes in each corner of the box and tighten.

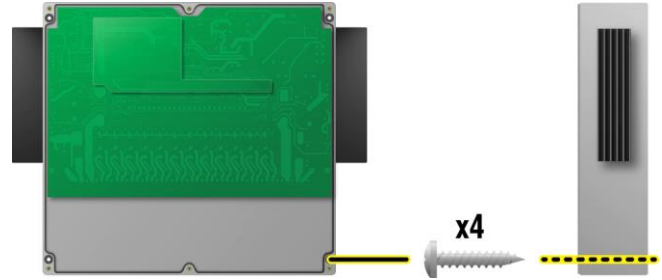

Connecting equipment to the HH-HMC-4



- ◇ Before connecting the incoming power, switch OFF the power at the source.
- ◇ Do not switch ON the power until you have finished all wiring and verified all equipment is properly connected and free of obstructions.



- ◇ Use the electrical knockouts for bringing wires or cables into or out of the HH-HMC-4 enclosure. Do not make additional holes in the enclosure; this can damage the watertight seal or control components and void the warranty.
 - ◇ The ratings of the equipment must not exceed the ratings of the HH-HMC-4 variable stages.
- Variable stage ratings:** 10 A at 120/230 VAC, general-purpose (resistive)
1200 W at 120 VAC; 2300 W at 230 VAC
- Variable stage fuses:** 15 A, 250 VAC ABC-type ceramic

Connecting heat mats

To control heat mats, you need to connect the following to the Heat Mat Control.

- ◆ Incoming power (120/230 VAC, 50/60 Hz)
- ◆ Heat mat
- ◆ Temperature probe

Temperature probe information

The HH-HMC-4 is compatible with heat mats that have an internal temperature probe (must be 1K Ω at 25°C), such as the Hog Hearth® heat mat.



Replace damaged probes as soon as possible. If there is no probe present or working properly, the control uses the set point as the current temperature.

Temperature probe installation guidelines

- ◆ Do not run the probe cable in the same conduit as AC power cables
- ◆ Do not run the probe cable beside AC power cables or near electrical equipment.
- ◆ When crossing other cables or power lines, cross them at a 90-degree angle.

To connect heat mats



The example in the diagram uses **VAR3** and **TEMP 3**. You can use any of variable outputs and any of the temperature inputs **except ROOM TEMP**.

1. Set the voltage selection switch to the correct line voltage.
2. Connect the incoming power and heat mat as shown in the diagram below.
3. Connect the temperature probe as shown in the diagram below.

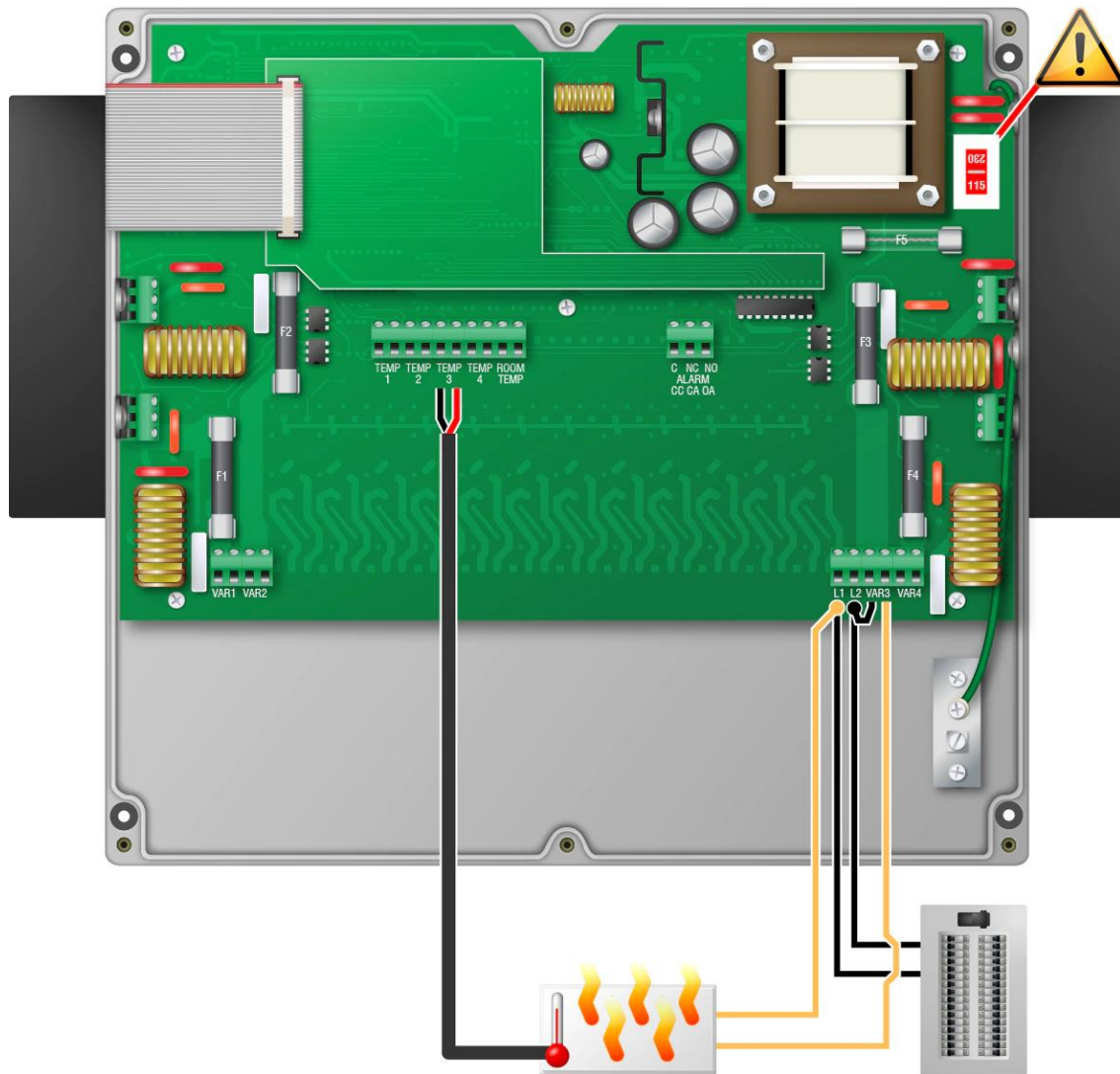

Connecting a probe for monitoring room temperature

You can connect a Phason 3K Series temperature probe to the **ROOM TEMP** terminal for monitoring temperatures in any room. Follow the same guidelines as connecting the temperature probes for heat mats.

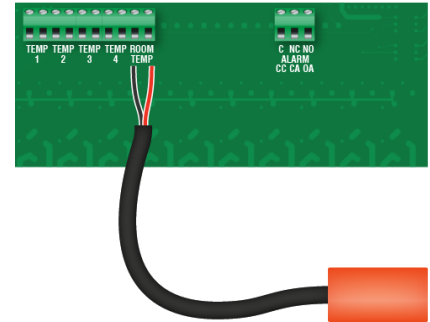

You can extend probe cables up to 500 feet. For more information, read the **Control Fundamentals** guide that came with your control.

Connecting an alarm system

You can connect an alarm system to the **ALARM** terminal on the HH-HMC-4. The alarm system can be a siren, alarm panel, auto-dialer, or similar equipment. Read your equipment's installation guide for information about the type of system: **normally open** or **normally closed**. Below are the descriptions for the alarm terminal.

- ◆ **CC:** common connection
- ◆ **CA:** closed on alarm
- ◆ **OA:** open on alarm

For the alarm system to sound (or dial out) during an alarm condition, you must enable the alarms. For more information, read **Programming alarms** on page 22.



The ratings of the siren or alarm system must not exceed the ratings of the HH-HMC-4 alarm relay.

Alarm relay ratings: 0.4 A at 125 VAC; 2 A at 30 VDC, resistive load
0.2 A at 125 VAC; 1 A at 30 VDC, inductive load

To connect a normally open alarm system

If you are connecting an alarm system with a **normally open connection**, meaning it **closes when there is an alarm**, connect it as shown in the normally open diagram.

If you are connecting the alarm system to more than one HH-HMC-4, join all the **CC** connections together and all the **OA** connections together. The alarm relays must be in parallel with each other so any of the controls can trigger the alarm system when an alarm occurs.

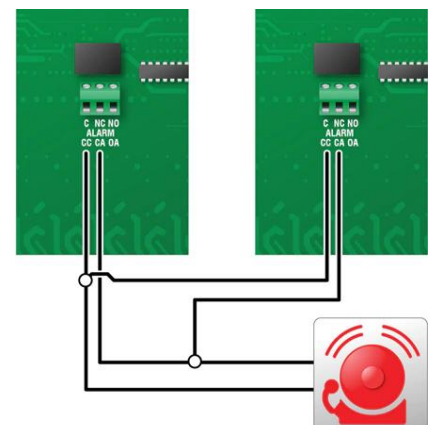

To connect a normally closed alarm system

If you are connecting an alarm system with a **normally closed** connection, meaning it **opens when there is an alarm**, connect it as shown in the normally closed diagram.

If you are connecting the alarm system to more than one HH-HMC-4, join the alarm relays in a continuous loop. The alarm relays must be in series with each other so any of the controls can trigger the alarm system when an alarm occurs.

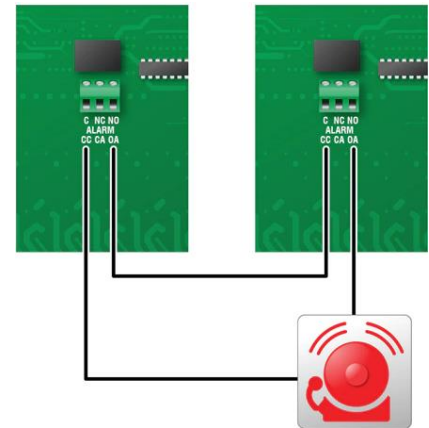

Finishing the installation

If you filled in the **Configuration worksheets** starting on page 37, make sure they correspond to the way the equipment is connected to the HH-HMC-4. It is very important that the connections and the worksheets are the same; you want to be sure you are configuring the equipment you think you are controlling.

1. Make sure all the wires are properly connected to the correct terminals.
2. Make sure the voltage selection switch is in the correct setting, 115 or 230 VAC.
3. Make sure the display cable is properly connected.
4. Switch on the power to the control.
5. When you switch on the power to the HH-HMC-4, the display should show the status screen. If the display does not come on, go back to step 0. If the display shows an alarm message, read **Programming alarms** on page 22.
6. Close the cover and then tighten the four screws.



Do not over tighten the screws. Do not use power screwdrivers or drills.

Configuration

Before you begin configure the HH-HMC-4, make sure:

- ◆ The control has power.
- ◆ All equipment has been properly connected to the correct terminals.
- ◆ You know which equipment is connected to which terminals.

Configuring the main control functions

Setting the clock

The HH-HMC-4 has a clock that keeps track of the time for the daily high and low temperatures and the for calculating settings for growth curves. If control has had no power for a long time, or time has switched between standard and daylight savings time, you will have to change the clock.

To set the clock

1. Press the **Menu** and then **Configuration**.
2. Below *Clock Type*, choose 12-hour or 24-hour.
3. Press **Unit Time**.
4. Press the **Up** or **Down** arrows to adjust the date and time.
5. Press **Save** when you are finished.

Selecting the units of measure

The HH-HMC-4 displays temperatures in either degrees Fahrenheit (°F) or degrees Celsius (°C). The factory default is °F. Follow the steps below if you want to change the temperature units.

To select the units

1. Press **Menu** and then **Configuration**.
2. *Below* Units, choose °C or °F.
3. Press **Save** when you are finished.

Configuring alarm silencing

Alarm silencing is the amount of time an alarm is temporarily disabled (silenced) after it has been acknowledged. Alarm silencing prevents the alarm relay from triggering immediately if it has been acknowledged when the alarm condition is still present. If the alarm condition is still present after the silencing duration, the alarm triggers again.

Default: 15 minutes

Range: 1 to 240 minutes (4 hours)

To configure alarm silencing

1. Press the **Menu** and then **Configuration**.
2. Press **Alarm Silencing**.
3. Press the **Up** or **Down** arrows to change the alarm silencing variation.
4. Press **Save** when you are finished.

Configuring groups and equipment

Configuring groups

The HH-HMC-4 has four groups available. Each group controls the outputs that are assigned to it. To configure a group, you need to do the following:

- ◆ Give the group a name
- ◆ Choose the control mode
- ◆ Choose the input the probe/sensor is connected to
- ◆ Choose the probe type
- ◆ Set the probe correction value

Control mode

The HH-HMC-4 can control heat mats according to a set point or a growth curve. A set point stays at the same value until you change it. A growth curve automatically adjusts set points as the animals grow.

Input

The HH-HMC-4 has four inputs specifically for connecting temperature probes that monitor heat mats. The group will control the heat mats according to the readings from the probe connected to this input.

Probe type

The HH-HMC-4 is compatible with heat mats that have an internal temperature probe (must be 1K Ω at 25°C), such as the Hog Hearth® heat mat. External 3K and 5K probes are available that are specifically designed to work with heat mats. For more information, contact your dealer.

Default: 1K

Options: 3K, 5K

Correction value

Probe correction allows you to adjust the temperature measured by the Heat Mat Control when using an external heat mat probe. You might want to use probe correction if the temperature measured is higher or lower than the temperature of the mat surface.

The probe correction value is an offset from the measured temperature. A negative value subtracts from the measured temperature, a positive value adds to it. For example, if the measured temperature is 70°F and the correction value is 2.5°F, the control will use and display 72.5°F.

Default: -6.0°F (-3.3°C)

Range: -9.0 to 9.0°F (-5.0 to 5.0°C)

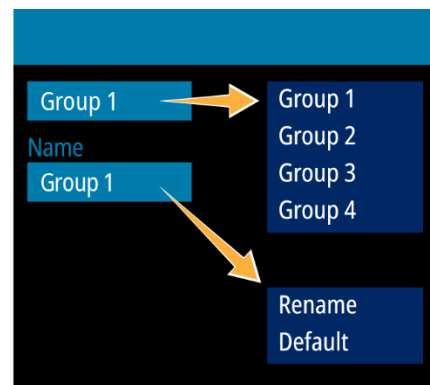
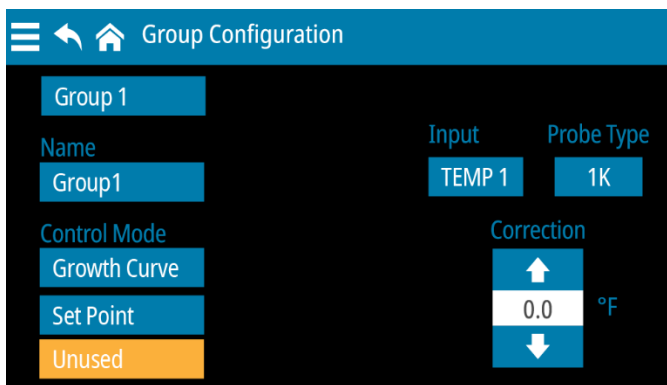

To configure groups

1. Press the **Menu** and then **Configuration**.
2. Press **Groups**.
3. Press the **Group #** button and then select the group you want to configure.
 - ◆ To give the group a name, press the **Name** button and then **Rename**.
 - ◆ To choose the control mode, press the button for the mode you want to use: *Growth Curve* or *Set Point*.



Choosing *Unused* will disable the group. The HH-HMC-4 will not control any outputs assigned to that group.

- ◆ To choose the input, press the **Input** button and then select the one that the group's temperature probe is connected to.
 - ◆ To change the temperature probe type from the default 1K (the one in the Hog Hearth Master Mat) press the **Probe Type** button and then choose one of the other options.
 - ◆ To change the temperature correction value, press the **Up** or **Down** arrows.
4. Press **Save** when you are finished.

Configuring outputs

You can assign any number of outputs (variable stages) to a group. The outputs will follow the programming of the group they are assigned to.

The HH-HMC-4 has four variable AC stages (**VAR 1** to **VAC 4**) to control heat mats. You can add 4 variable DC stages and expand the capacity of your control using Expansion Boxes. For more information, see **Replacement kits and optional accessories** on page 33.

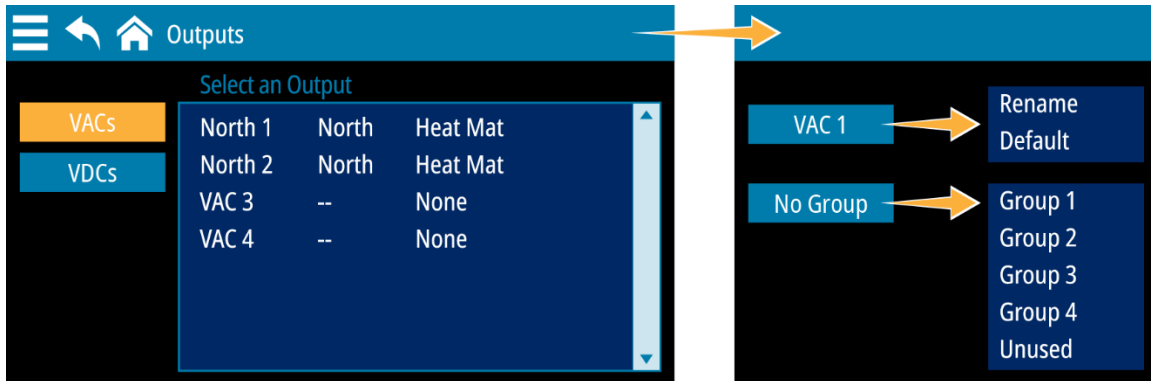

To configure outputs

1. Press the **Menu** and then **Configuration**.
2. Press **Outputs**.
3. Select which type of output you want to configure, **VACs** (variable AC) or **VDCs** (variable DC). The configuration process is the same for each.
4. Press the output you want to configure.
5. You can rename outputs, assign them to groups, or remove them from groups.
 - ◆ To rename the output, press the **Output** button and then **Rename**.
 - ◆ To assign the output to a group, press the **Group** button and then one of the four groups.
 - ◆ To remove the output from a group, press the **Group** button and then **Unused**.
6. Press **Save** when you are finished.

Configuring a room temperature probe

You can connect a Phason 3K Series temperature probe to the **ROOM TEMP** terminal for monitoring temperatures in any room. The current reading and daily low and high temperatures will display on the Status screen.

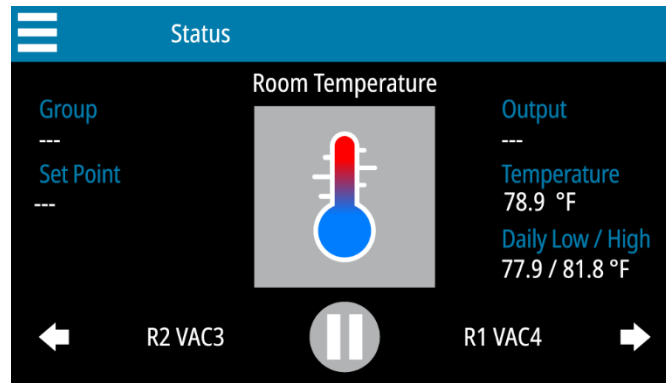

To configure a room temperature probe

1. Press the **Menu** and then **Configuration**.
2. Below *Room Probe*, press **On**.
3. Press **Save** when you are finished.

Settings



◇ You must configure the HH-HMC-4 before programming the settings.



◇ Use **Settings worksheets** on page 38 when programming the HH-HMC-4.

Programming group settings

Programming growth curves

A growth curve automatically adjusts temperature set points over time, up to a maximum of 365 days. There are seven steps in a growth curve; each step has a start day and a temperature. The HH-HMC-4 calculates the set points for each day between the steps and then adjusts them each day at midnight.

A simple example

Step 2 starts on day 5 and has a temperature of 84.0°F.
Step 3 starts on day 10 and has a temperature of 82.0°F.

The difference between the step 2 and step 3 set points is 2.0°F:
(84.0 – 82.0 = 2.0).

There are 5 days in step 2: (10 – 5 = 5).

The control divides the temperature difference by the number of days, $2.0 \div 5 = 0.4$, and then automatically adjusts the set point by 0.4°F each day for 5 days.

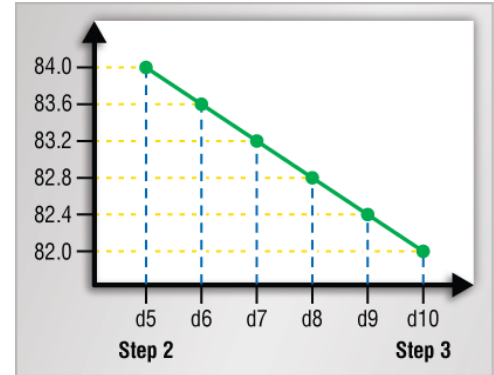

Current day

When a growth curve is enabled, the HH-HMC-4 automatically advances the current day and adjusts the set point each day at midnight. However, there may be times when you want to adjust the day forward or backward. You can do that easily by changing the current day of the curve.

Restart day

The restart day defines the duration of the growth curve. By default, when a growth curve is finished its last day, the Heat Mat Control maintains the final set point until you restart the curve. Optionally, you can program the control to restart the curve after any number of days, up to 365. The growth curve will reset at the **beginning** of the that day.

Default: 64

Range: 1 to 365



- ◇ You can restart a growth curve from the home screen. For more information, read **Monitoring your control** on page 25.
- ◇ Use the **Growth curve worksheet** on page 39 when programming growth curves.

NOTE

- ◇ If a growth curve is controlling the group, you cannot adjust the group set point.

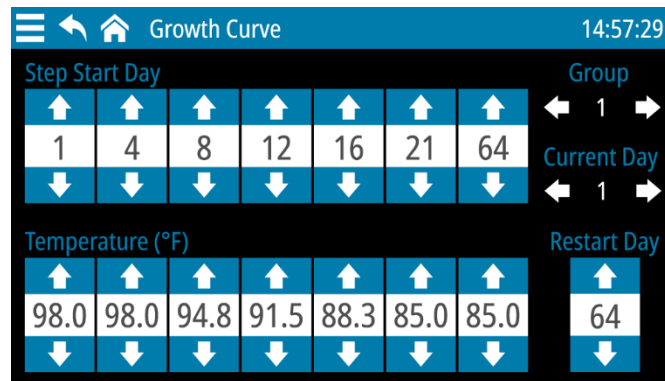

To program growth curves

1. Press the **Menu** and then **Settings**.
2. Press **Growth Curves**.
3. Below *Group*, press the **Left** or **Right** arrow to choose the group/curve you want to adjust.
4. Below *Step Start Day*, press the **Up** or **Down** arrow to set the start day for each step.
5. Below *Temperature*, press the **Up** or **Down** arrow to set the temperature for the start day of each step.
6. Below *Restart Day*, press the **Up** or **Down** arrow to set the day.
7. Press **Save** when you are finished.

To change the current day

1. Press the **Menu** and then **Settings**.
2. Press **Growth Curves**.
3. Below *Group*, press the **Left** or **Right** arrow to choose the group/curve you want to adjust.
4. Below *Current Day*, press the **Left** or **Right** arrow to choose the day.
5. Press **Save** when you are finished.

Programming the group set point

The group set point is the target temperature for the surface of the heat mat. The HH-HMC-4 continually monitors the temperature and provides the optimal output to maintain the target temperature.

Default: 99.0°F (37.2°C)

Range: -13 to 125°F (-25 to 51.7°C)

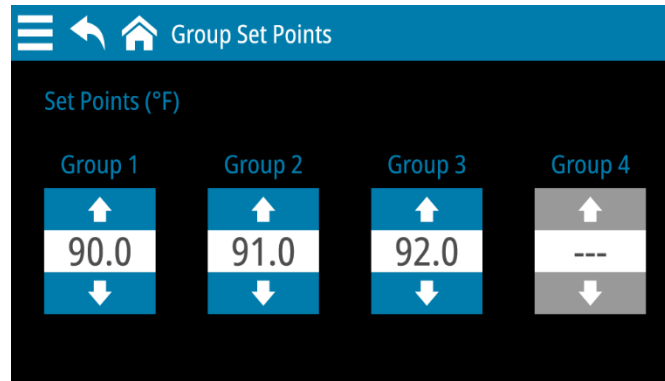

If a group is greyed out, that group is configured to use a growth curve or as unused. You cannot adjust the set point for that group.

To program the group set point

1. Press the **Menu** and then **Settings**.
2. Press **Group Set Point**.
3. Press the **Up** or **Down** arrows to change the set points for the groups you want to adjust.
4. Press **Save** when you are finished.

Programming alarms

There are four alarm conditions: high temperature, low temperature, control power failure, and temperature probe failure.

When the temperature is above the high temperature alarm setting or below the low temperature alarm setting, there is an alarm condition. If the alarm condition is present for one continuous minute, the control activates the alarm relay and displays the alarm message on the home screen. The minimum duration prevents alarms from occurring when the temperature rises or drops for just a few seconds.

When the temperature returns to the normal range, the control deactivates the alarm relay. The alarm message will remain until you acknowledge it.

Example

For example, say the high temperature alarm setting is 105 degrees Fahrenheit. If the temperature rises to 106 degrees, but drops below 105 degrees 30 seconds later, the alarm relay does not activate. If the temperature rises to 106 degrees and stays there for more than 1 minute, the alarm relay activates. The alarm relay remains activated until the temperature drops below the alarm setting.

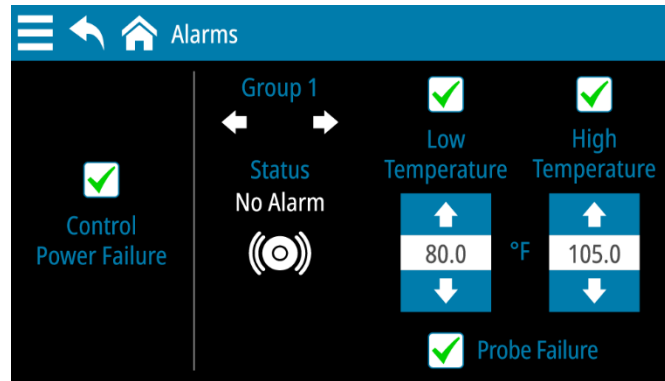
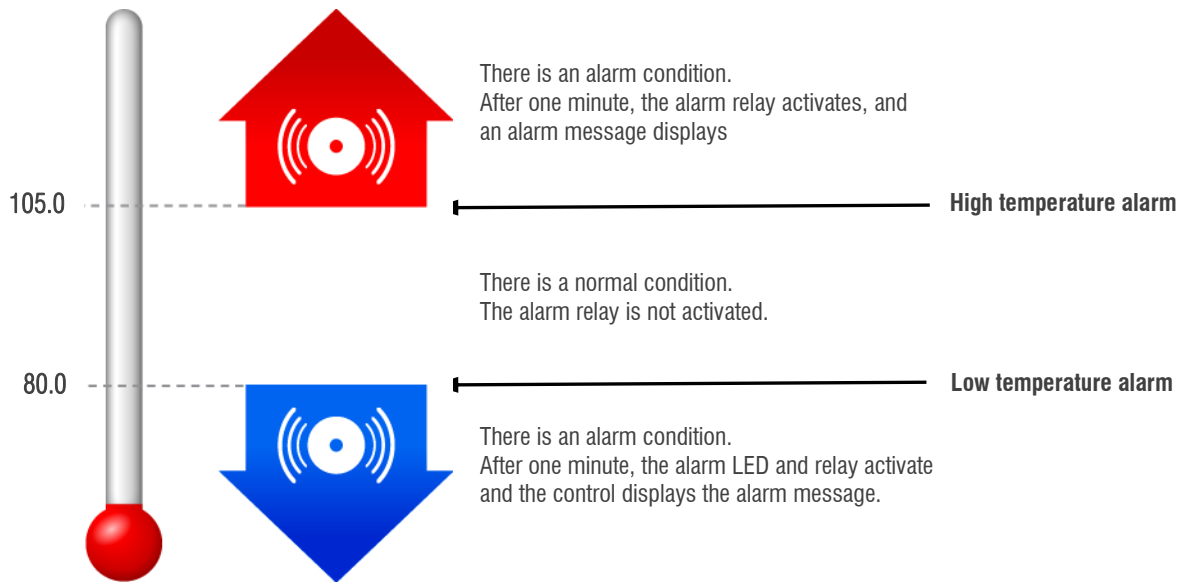

To enable, disable and program alarms

1. Press the **Menu** and then **Settings**.
2. Press **Alarms**.
3. Below *Group*, press the **Left** or **Right** arrow to choose the group you want.
 - ◆ To enable or disable an alarm, press the checkbox beside the one you want to enable. There is a check in the box when enabled.
 - ◆ To adjust the temperature set points, Press the **Up** or **Down** arrows.
4. Press **Save** when you are finished.

Using settings groups

Settings groups allow you to have different configuration and settings for different situations. For example, you can have a settings group for each of the different seasons. When you transition from one season to another, you can switch to another settings group without having to reprogram the control each time.

You can create up to four settings groups. Each settings group has its own settings and configuration. All settings and configuration except date, time, and screen lock can be different for each group.

Only one settings group can be active. Changes you make in any of the settings and configuration screens will apply only to the active settings group. You can scroll through each settings group and view the settings group control configuration by pressing the left or right arrows.

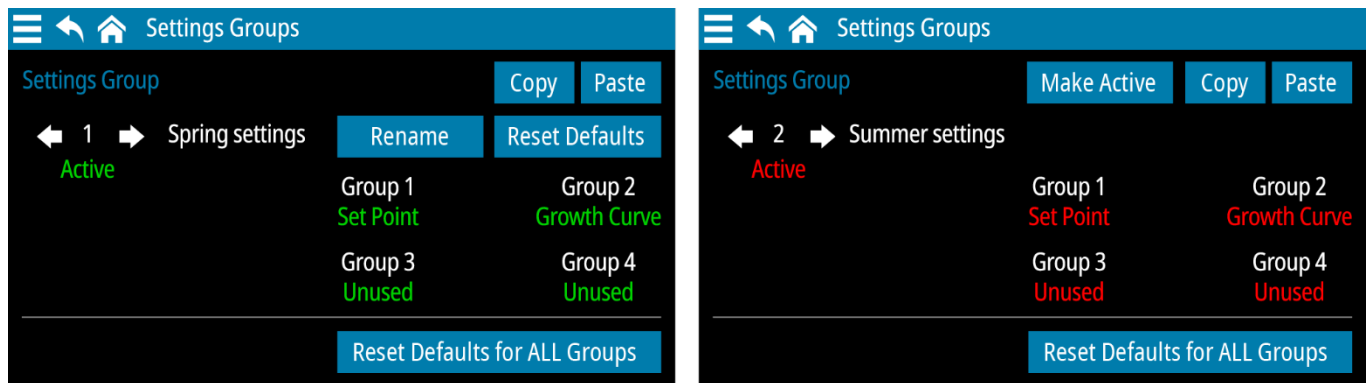

To activate a settings group

1. Press the **Menu** and then **Settings**.
2. Press **Settings Groups**.
3. Press the **Left** or **Right** arrow to choose the settings group you want to activate and then press **Make Active**.
The control will restart and then the selected settings group will be active.

To rename a settings group



A settings group must be active before you can rename it.

1. Press the **Left** or **Right** arrow to choose the settings group you want to rename.
2. Press **Rename**.

To copy one settings group to another

1. Press the **Left** or **Right** arrow to choose the settings group you want to copy.
2. Press **Copy**. Confirm by pressing **Yes**.
3. Scroll to the group you want to copy the settings to.
4. Press **Paste**. Confirm by pressing **Yes**.

To reset the active group to factory defaults

1. Make sure the group you want to reset is the active group.
2. Press **Reset Defaults**.
A confirmation and warning message displays.
3. To restore the factory defaults for the group, press **Yes**. To cancel, press **No**.

To reset all groups to factory defaults

1. Press **Reset Defaults for ALL Groups**.
A confirmation and warning message displays.
2. To restore factory defaults for all groups, press **Yes**. To cancel, press **No**.

Daily operation and maintenance**Monitoring your control**

The Status screen displays information about each probe and heat mat. Each piece of equipment has its own status screen. The HH-HMC-4 automatically scrolls through each screen. Here are two examples.

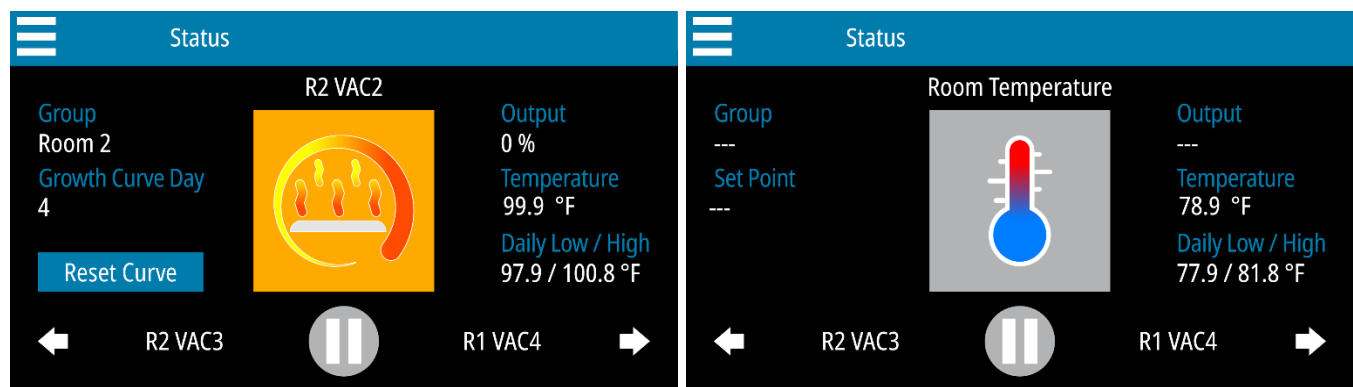

- ◆ To manually scroll through the screens, press the Left or Right arrows.
- ◆ To stop or start scrolling, press the **Pause/Play** button.

In the center of each status screen is a widget. The following tables list the meaning of the button colors and icons.

Equipment



Temperature



Variable heating

Status



Light gray

A probe in normal status



Dark gray

Equipment that is off



Green

Equipment or probe that is in manual override



Orange

Heating equipment that is on



Red

Equipment or probe that has an alarm condition

Widgets

Pressing the widget in the center of the status screen takes you to the widget screen for the selected probe or heat mat. Widget screens allow you to switch between automatic and manual control, view the current and daily high and low temperatures, and view settings.

Acknowledging and silencing alarms

An alarm occurs if an enabled alarm condition is present for longer than the minimum duration of one minute. The one-minute minimum duration prevents alarms from occurring when the temperature rises or falls or just a few seconds. When an alarm occurs, the alarm relay triggers and a message flashes on the screen.

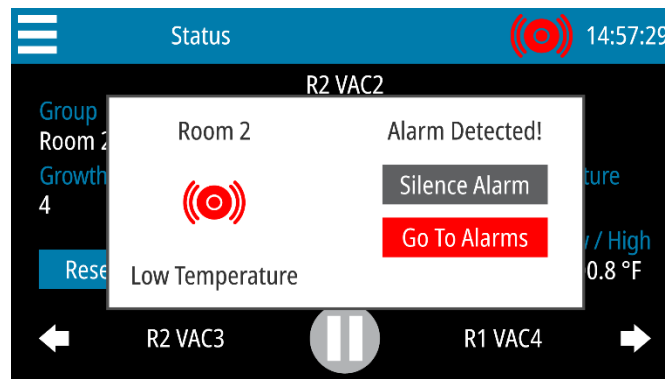

To acknowledge and silence alarms

Press **Silence Alarm**.

This will clear the message and switch off the alarm for the alarm silencing duration.



- ◇ The widget background will be red and the alarm silenced icon will flash at the top of the screen until the problem that caused the alarm has been fixed.



- ◇ If the problem is not resolved by the end of the silencing duration, the alarm relay will trigger and the message will display again.
- ◇ For more information, read **Configuring alarm silencing** on page 15.

Logs

There are three types of logs: *daily*, *10-minute*, and *alarm*.

Daily log

- ◆ For groups, the Daily log shows the set point and daily minimum and maximum temperatures. If the set point changed during the day, the log shows only the latest one.
- ◆ For room probes, the log shows the daily minimum and maximum temperatures.

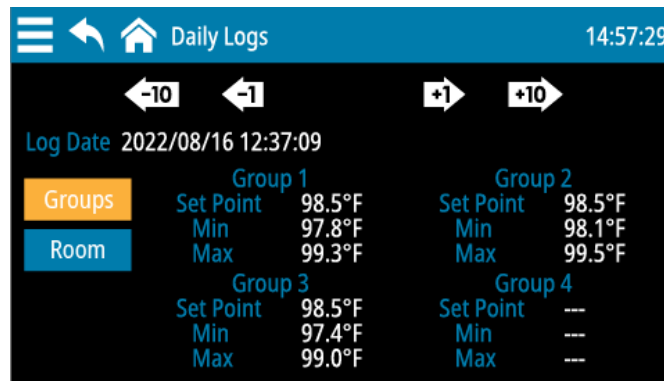

Alarm log

- ◆ The Alarm log shows the alarm type, the source (group), and the condition (reading) that caused it.

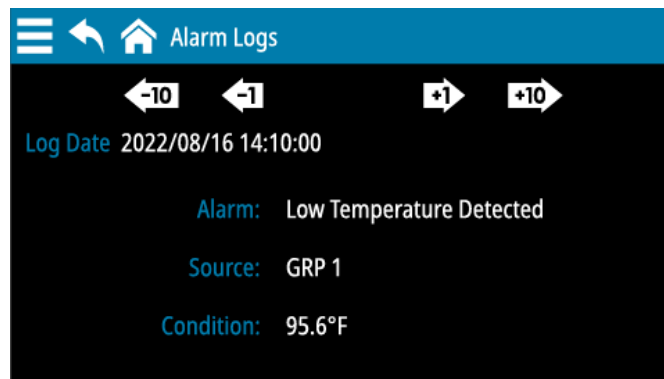

10-minute log

- ◆ For groups, the 10-minute log shows the set point and temperature.
- ◆ For room probes, the log shows the temperature.
- ◆ For the VACs and VDCs, the log shows the group name and the percentage of output.

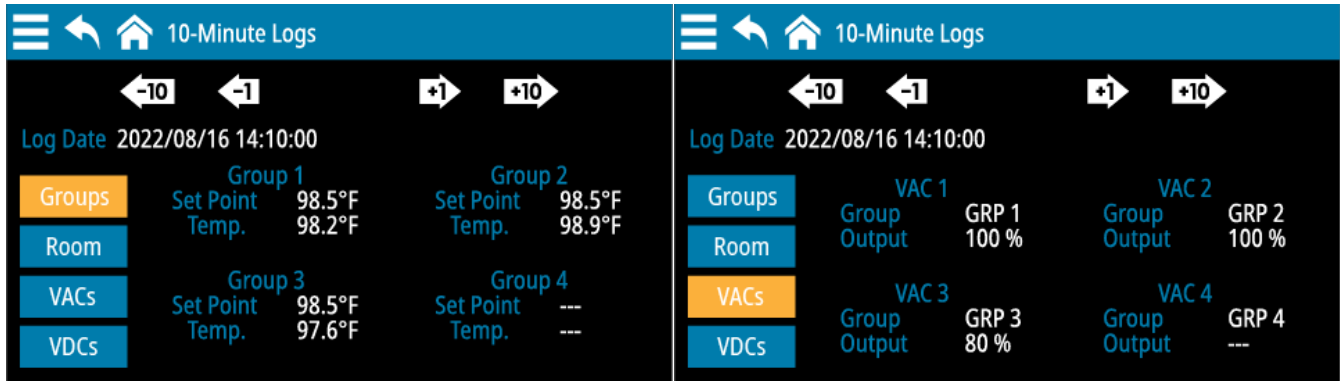

To view logs

1. Press the **Menu** and then **Administration**.
2. Press **Check Logs**.
3. Press the button for the log you want to view.
 - ◆ Press the left or right arrows to scroll through the logs.
 - ◆ Press the button for the type of information you want to see.

Testing probes and equipment

Using manual override

Manual override allows you to override the power to one or more outputs. Manual override is useful for testing equipment and settings, or for diagnosing problems.

To override outputs

Option 1 - single output

1. Press the **Home** button to go to the Status screen.
2. Press the Left or Right arrows to select the output/heat mat you want to override.
3. Press the widget button (the colored button in the center of the screen).
4. Press the **Up** or **Down** arrows to adjust the power to the output.
HH-HMC-4 automatically puts the item to manual override.
5. When finished, press **Auto** to return to automatic mode.

Option 2 – single or multiple outputs

1. Press the **Menu** and then **Manual Override**.
2. Press the output you want to override.
3. Press the **Up** or **Down** arrows to adjust the power to the output.
HH-HMC-4 automatically puts the item to manual override and displays a manual override icon.
4. Repeat steps 2 and 3 for each output you want to override.
5. When finished, press **Auto** to return the selected output to automatic mode, or **Auto All** to return all outputs to automatic mode.



When you are finished, set all outputs to automatic control. Any outputs that you do not set to automatic will not function according to normal, programmed settings and will remain in manual override.

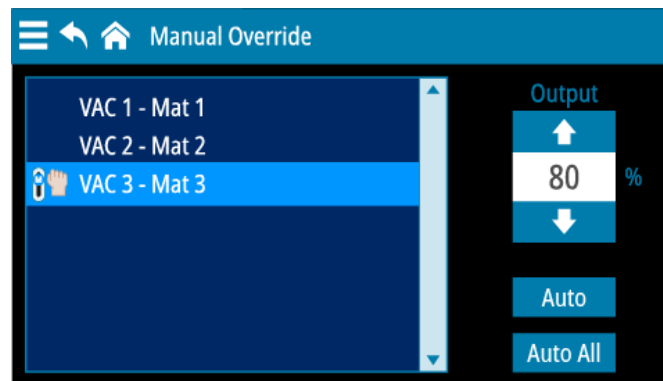

Using screen lock security

The HH-HMC-4 has a screen lock feature you can use to control who makes changes to the control's settings. By default, screen lock is *not enabled*.

While screen lock is enabled, users can see the status screen but cannot access any of the control's functions. After entering the PIN, users will have access to all functions. The control will not ask for a PIN again unless the user locks the screen. The PIN number is a four-digit number you choose.

Locked override option

When the locked override option is enabled, users will be able to manually override equipment while the screen lock is enabled, even without entering a PIN. They will not be able to access any other functions.

To enable screen lock and set the PIN

1. Press the **Menu** and then **Administration**.
2. Press **Configure Screen Lock**.
 - ◆ To enter a new PIN, press a new four-digit number. The control will accept the last four numbers you press.
 - ◆ To enable or disable screen lock or the locked override option, press the **Enabled** or **Disabled** button for that option.Press **Save** when you are finished.

To lock the screen

Press the **Menu** and then **Screen Lock**.

To unlock the screen

1. Press the **Lock** and then enter the four-digit PIN.
2. Press **Unlock Screen**.

NOTE

If the PIN has been forgotten and nobody can access the control, contact your dealer.

Servicing and maintaining your HH-HMC-4

Restoring the factory defaults

Resetting the HH-HMC-4 erases all the configuration and settings you programmed and restores them to what they were when the control left the factory. For a list of the factory defaults, read **Appendix B: Factory defaults** on page 36.



- ◆ **Restore the factory defaults only as a last resort. It erases ALL your configuration and settings and you will have to reconfigure the control.**
 - ◆ If you restore the HH-HMC-4 to its factory defaults, disconnect the power to all loads and then reconfigure the control before restoring power to the loads.
-

To restore the factory defaults

1. Press the **Menu** and then **Administration**.
2. Press **Restore Defaults**.
3. To restore defaults and remove all your configuration and settings, press **Yes**. To cancel and return to the menu, press **No**.

Saving and restoring settings

You can save or restore (load) your settings and configuration from any USB drive. You can also transfer them to any HH-HMC-4 and set up new controls in seconds.



- ◇ We recommend regularly saving your configuration and settings to a USB drive and then keeping the drive in a safe place. This allows you to quickly set up new controls or recover your information if you install a display kit.



- ◇ The file created when saving settings to USB contains **all four settings groups** in one file.
- ◇ When you load settings from USB, the control overwrites **all four settings groups**, and then restarts. The settings group that was active before restarting will again be active.
- ◇ For more information about settings groups, read **Using settings groups** on page 24.

To save to USB

1. Loosen the four screws in the HH-HMC-4 enclosure and then gently open the cover. Be careful not to disconnect the ribbon cable.
2. Insert a USB drive into the USB port on the inside of the cover.
3. Press the **Menu** and then **Administration**.
4. Press **Save to USB**.
5. To save the configuration and settings, press **Yes**. To cancel and return to the menu, press **No**.
6. Remove the USB drive.
7. Replace the cover and then tighten the four screws.

To load from USB

1. Loosen the four screws in the HH-HMC-4 enclosure and then gently open the cover. Be careful not to disconnect the ribbon cable.
2. Insert the USB drive containing the configuration and settings into the USB port on the inside of the cover.
3. Press the **Menu** and then **Administration**.
4. Press **Load from USB**.
5. To load the saved configuration and settings, press **Yes**. To cancel and return to the menu, press **No**.
6. Remove the USB drive.
7. Replace the cover and then tighten the four screws.

Displaying version information

Firmware is like an operating system for your computer or mobile device. Firmware contains instructions that tell HH-HMC-4 how it operates. Just like operating systems such as Windows or Android have version numbers, the HH-HMC-4 firmware has a version number. The HH-HMC-4 displays the firmware version as a number in the format v#.##.

If you need to contact customer support about the HH-HMC-4, you might need to provide them with the firmware version of your control. For more information about customer support, read **Service and customer support** at the back of the manual.

To display version information

Press the **Menu** and then **About**.

Updating the firmware

Improvements and new capabilities are occasionally added to the HH-HMC-4. You can upgrade the firmware in your control when these become available. The update takes about 20 to 30 seconds.



- ◇ To get an update file, contact your dealer.



- ◇ The USB drive must be formatted as a **FAT32 file system**.
- ◇ You must copy the file to the **root** of the USB drive. The root means **not in a folder**.
- ◇ The following instructions are for a Windows computer.

To prepare the firmware update file

1. Insert the USB drive into your computer and then open Windows Explorer.
2. Right-click the USB drive
3. Select **Properties**.
4. Verify the file system is FAT32. If the file system is not correct, you will need to format the drive as FAT32, or use a different USB drive that is the correct format.
5. Copy the update file to the **root** of the USB drive.
6. Remove the drive.

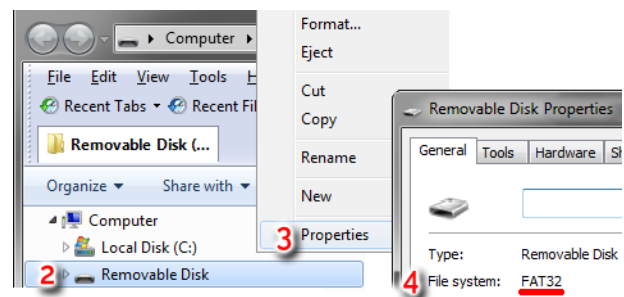

To update the firmware

1. Loosen the four screws in the HH-HMC-4 enclosure and then gently remove the cover. Be careful not to disconnect the ribbon cable.
2. Insert the USB drive containing the update into the USB port on the inside of the cover.
3. Press the **Menu** and then **Administration**.
4. Press **Update Firmware**.
5. To update the firmware, press **Yes**. To cancel and return to the menu, press **No**.
6. After the update has finished, remove the USB drive.
7. Verify the control operates properly.
8. Replace the cover and then tighten the four screws.



- ◇ If there is a problem during the update, leave the USB drive connected and follow these steps.
 - ◇ Switch off the power to the HH-HMC-4 for 10 seconds, and then switch it on again. The control should automatically update when it restarts.
-

Replacement kits and optional accessories

Replacement kits and optional accessories are available to enhance and extend the capabilities of the HH-HMC-4.

Replacement kits

If the HH-HMC-4 display or bottom circuit board fails, you can replace it with a kit.

Display kit

Display kit is model **HH-HMC-4-KDISP**. You will need reprogram control after replacing the display.



If you have saved your configuration and settings to a USB drive, you can restore them instead of having to reconfigure and program the control.

Control kit

The control kit is model **HH-HMC-4-KCON**.

Accessories

Phason 3K Series temperature probes and extension cable

Phason 3K Series temperature probes monitor temperatures ranging from -49 to 122°F (-45 to 50°C). The probes are available in 1, 6, 30, 75, or 150-foot cable lengths and can be extended up to 500. Extension cable is available in 500-foot lengths.



Variable DC Module

The Variable DC Module (model VDC-4) has four 0 to 10 V outputs for controlling Expansion Boxes. Each of the four outputs can have up to 10 Expansion Boxes connected to it.

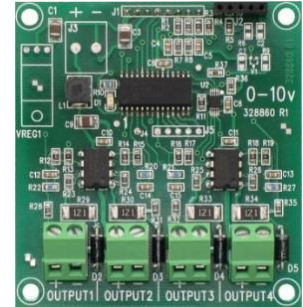

Expansion Boxes

Expansion Boxes are an affordable way to increase the capacity of the HH-HMC-4. Expansion Boxes take the 0 to 10 V signal from the VDC-4 module and then adjust heat mat output accordingly. Expansion Boxes are easy to install and require *no additional programming*. Each Expansion Box connected to an output on a VDC-4 module will follow the settings you programmed into the HH-HMC-4 for that output.

HH-HMC-4-EX120



There are two models available:

- ◆ HH-HMC-4-EX120 with 1 × 20 A output
- ◆ HH-HMC-4-EX210 with 2 × 10 A outputs

HH-HMC-4-EX210

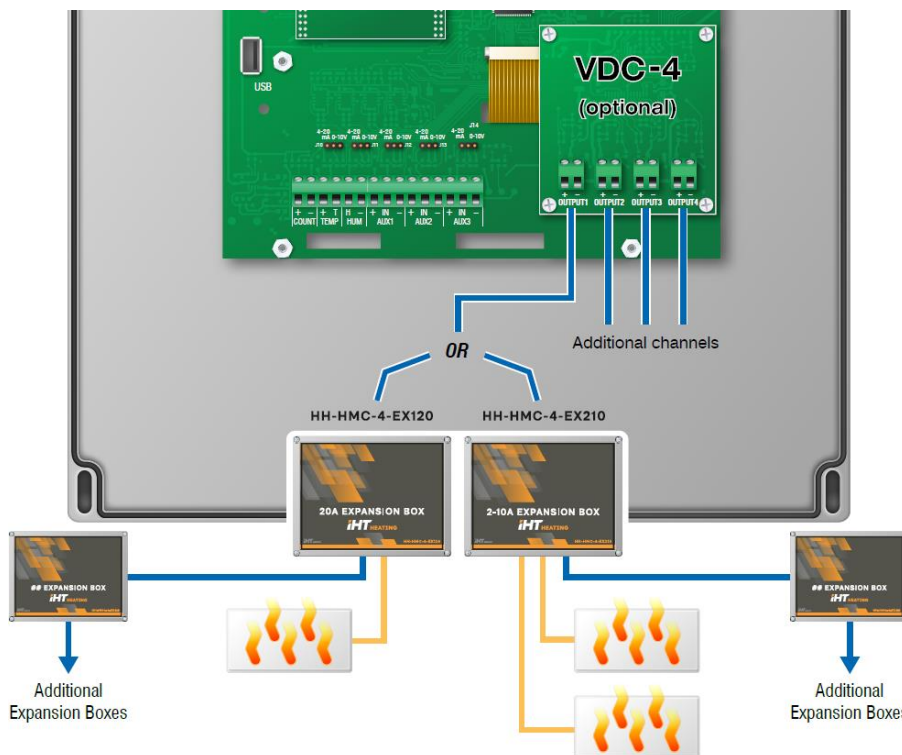

Appendixes

- ◆ **Appendix A: Troubleshooting** below
- ◆ **Appendix B: Factory defaults** on page 36
- ◆ **Appendix C: Worksheets** on page 36

Appendix A: Troubleshooting

Problem	Possible causes	Possible solutions
Cannot access the menu or settings	Screen lock security is enabled.	Enter the correct PIN. For more information, read Unlocking the screen on page 6.
An output is not displaying on the status screen	The group the output is assigned to does not have a control mode configured, or does not have temperature probe.	Make sure the group has a control mode (group set point or growth curve) and an input configured. For more information, read Configuring groups on page 16.
Power supply components blown out or burn marks on boards and components	Power surge, brownout, or power outage	Avoid the problem in future by providing proper voltage and protection for the control.
No power and/or display	A circuit breaker at service panel is off or tripped.	Reset the circuit breaker.
	Incorrect wiring	Correct the wiring.
	The cable from the display is not connected to the control board properly.	Plug in the display board cable. For more information, read Bottom layout on page 9.
	The 115/230 VAC switch is in the wrong position.	Switch off the power, set the switch to the correct setting, and then switch on the power. For more information, read Bottom layout on page 9.
Temperature does not change or is unusually high or low	There are no working temperature probes enabled.	Make sure at least one working probe is enabled. For more information, read Configuring groups on page 16.
	The wrong probe type is configured.	Configure the group for the correct probe type. For more information, read Probe type on page 16.
	An incompatible temperature probe is connected.	Remove the incompatible probe and then install a compatible one. For more information, read Temperature probe information on page 11.
	The extension cable connected to the temperature probe has a poor connection.	Check the extension cable connection. Resolder it if necessary.
	Damaged probe	Replace the temperature probe.
Alarm relay not operating alarm system	Incorrect wiring	Correct the wiring. For more information, read Connecting an alarm system on page 13

Appendix B: Factory defaults

The HH-HMC-4 leaves the factory with default configuration and settings. Resetting the HH-HMC-4 erases all the configuration and settings you programmed and restores them to what they were when the control left the factory. For more information, read **Restoring the factory defaults** on page 30.

Configuration			Growth curve			
Groups	Not configured		Current day	1		
Outputs	Not configured		Restart day	64		
Probe type	1K		Default type	Winter curve	Summer curve	
Screen lock	Off		Step 1	Day 1	98.0°F	95.0°F
Alarm silencing	15 minutes		Step 2	Day 4	98.0	95.0
Units	Fahrenheit		Step 3	Day 8	94.8	91.8
Frequency	60 Hz		Step 4	Day 12	91.5	88.5
Room probe	Off		Step 5	Day 16	88.3	85.3
Clock type	24-hour		Step 6	Day 21	85.0	82.0
			Step 7	Day 64	85.0	82.0

Alarm settings			Group set point	
High temperature	Enabled	105.0°F	Group set point	99.0°F
Low temperature	Enabled	60.0		
Power failure	Enabled			
Probe failure	Enabled			

Appendix C: Worksheets

Installation worksheet



Use the **Installation worksheet** when you fill in the **Configuration worksheets** (starting on page 37).

Electrical ratings

Input power	120/230 VAC, 50/60 Hz
Control fuse [F5]	1 A, 250 VAC fast-acting glass
Variable AC stages	10 A at 120/230 VAC, general-purpose (resistive) 1200 W at 120 VAC; 2300 W at 230 VAC
Fuses [4: F1 to F4]	15 A, 250 VAC ABC-type ceramic
Alarm relay	0.4 A at 125 VAC; 2 A at 30 VDC, resistive load 0.2 A at 125 VAC; 1 A at 30 VDC, inductive load

Equipment to connect

Variable AC outputs

VAC 1

VAC 2

VAC 3

VAC 4

Variable DC outputs ①

VDC 1

VDC 2

VDC 3

VDC 4

Temperature probes

TEMP 1

TEMP 2

TEMP 3

TEMP 4

ROOM TEMP ②

Alarm relay

ALARM

① Requires optional VDC-4 Variable DC Module

② Phason 3K Temperature probe only

Configuration worksheets



Use the **Installation worksheet** on page 36 when completing the configuration worksheets.

Main control function worksheet

For more information, read **Configuring the main control functions** on page 15.

Item	Configuration
Units	°F °C
Room probe	ON OFF
Clock type	12-hour 24-hour

Item	Configuration
Alarm silencing	(minutes)
Frequency	(Hz)

Group configuration worksheet

For group configuration information, read **Configuring groups** on page 16.

Group	Name/description	Control mode			Temp input				Probe type			Correction (°F/C)
1		Growth curve	Set point	Not used	1	2	3	4	1K	3K	5K	
2		Growth curve	Set point	Not used	1	2	3	4	1K	3K	5K	
3		Growth curve	Set point	Not used	1	2	3	4	1K	3K	5K	
4		Growth curve	Set point	Not used	1	2	3	4	1K	3K	5K	

Output configuration worksheet

For configuration information, read **Configuring outputs** on page 18.

Output	Name/description	Group assignment			
VAC 1		1	2	3	4
VAC 2		1	2	3	4
VAC 3		1	2	3	4
VAC 4		1	2	3	4

Output	Name/description	Group assignment			
VDC 1 ^①		1	2	3	4
VDC 2		1	2	3	4
VDC 3		1	2	3	4
VDC 4		1	2	3	4

^① Requires optional VDC-4 Variable DC Module

Settings worksheets

Settings worksheets are for you to use when programming the HH-HMC-4 settings. Each worksheet contains a brief explanation of the information required. For more information about programming the HH-HMC-4, see **Settings** on page 19.

Growth curve worksheet

A growth curve automatically adjusts the temperature set points over time to control the temperature. You can have up to seven steps in a growth curve. Each step has a start date and temperature. HH-HMC-4 automatically calculates the set points for the days between the steps and adjusts the set points at midnight each day. For more information, read **Programming growth curves** on page 20.

Step	Start day	Temperature
1		
2		
3		
4		
5		
6		
7		
Restart day		

Step	Start day	Temperature
1		
2		
3		
4		
5		
6		
7		
Restart day		

Step	Start day	Temperature
1		
2		
3		
4		
5		
6		
7		
Restart day		

Step	Start day	Temperature
1		
2		
3		
4		
5		
6		
7		
Restart day		



- ◇ Temperature range: -13 to 125°F (-25 to 51.7°C)
- ◇ Temperature set points must decrease as the steps increase.

Alarm settings worksheet

The alarm settings for the HH-HMC-4 determine which alarm conditions are enabled and their settings. The alarm relay activates if an alarm condition that is enabled is present for longer than the minimum duration of one minute. The minimum duration prevents alarms from occurring when the temperature rises or falls for just a few seconds. For more information, read **Programming alarms** on page 22.

Alarm	Status	Set point	Description
High temperature	Enabled Not enabled		The highest temperature that you can safely allow the heat mats to rise to — it cannot be lower than low temperature alarm.
Low temperature	Enabled Not enabled		The lowest temperature that you can safely allow your heat mats to fall to — it cannot be higher than high temperature alarm.
Probe damage	Enabled Not enabled	-----	The temperature probe is damaged or disconnected.
Power failure	Enabled Not enabled	-----	There has been a power interruption.

The temperatures can range from -13 to 125°F (-25 to 51.7°C)

Service and customer support

Your dealer will be happy to answer all technical questions that will help you use the HH-HMC-4. Before contacting your dealer, check the following:

- ◆ Read this manual for information about the feature with which you are having trouble.
- ◆ If you are having a problem using the HH-HMC-4, look in **Appendix A: Troubleshooting** on page 35 and follow the directions for correcting the problem.
- ◆ If you still have a problem with the HH-HMC-4, collect the following information:
 - ◆ The serial number
 - ◆ Any messages displayed by the HH-HMC-4
 - ◆ A description of the problem
 - ◆ A description of what you were doing before the problem occurred



- ◇ Innovative Heating controls are designed and manufactured to provide reliable performance, but they are not guaranteed to be 100 percent free of defects. Even reliable products can experience occasional failures and the user should recognize this possibility.
 - ◇ If Innovative Heating products are used in a life-support ventilation system where failure could result in loss or injury, the user should provide adequate back up ventilation, supplementary natural ventilation, or an independent failure-alarm system. The user's lack of such precautions acknowledges their willingness to accept the risk of such loss or injury.
-

Innovative Heating

205 Oakland Road
Oak Bluff, Manitoba, Canada
R4G 0A4

Phone: 204-896-7500
Toll free: 800-728-9661
Fax: 204-885-0903

E-mail: hoghearth@ihtech.ca
Web: innovativeheatingtech.com

HH-HMC-4

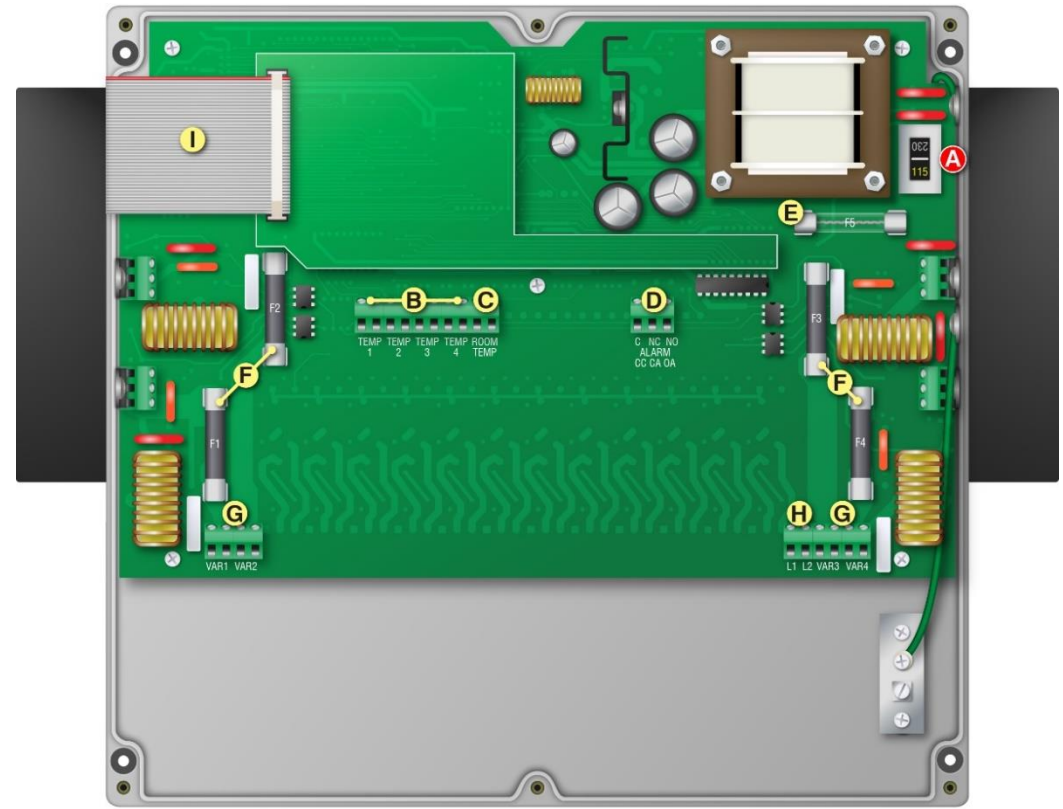
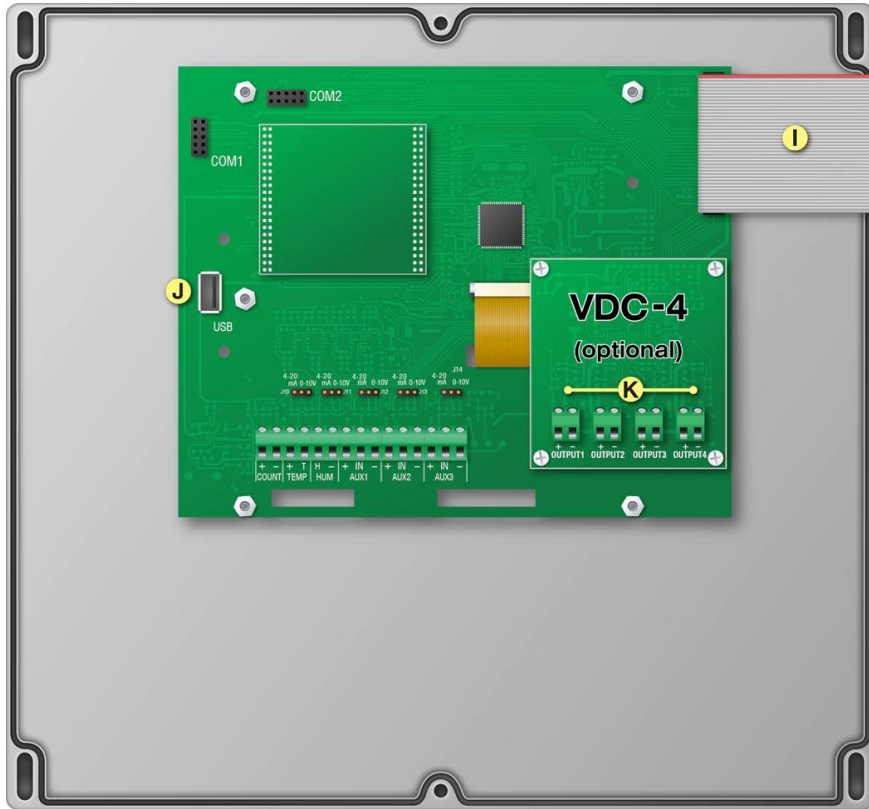
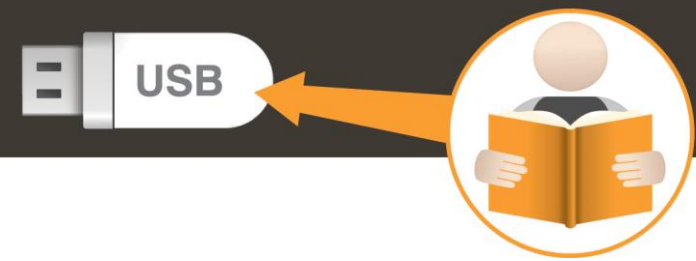

(A) Voltage switch ⚠️ Set the switch to the correct line voltage.

(B) Temperature [TEMP1 to TEMP4]

Connect the primary 3K Series temperature probe to TEMP1. Connect any additional 3K Series probes to the other terminals.

(C) Room temperature (ROOM TEMP)

Connect a 3K Series probe for monitoring room temperatures.

(D) Alarm relay

Connect an external alarm system or siren.

(E) Control fuse

The fuse for the main control

(F) Fuses [F1 to F4]

Fuses for variable stages: F1 for VAR1, F2 for VAR2, and so on.

(G) Variable stages [VAR1 to VAR4]

Connect variable speed fans or heating equipment.

(H) Incoming power

Connect the incoming power from the panel.

(I) Display cable

Disconnect the cable during installation. Reconnect it when done.

(J) USB

Connect a USB drive when saving / loading settings or upgrading.

(K) VDC-4 [OUTPUT1 to OUTPUT4]: Connect variable frequency drives (VFDs) or other equipment that requires a 0 to 10 V DC signal input.

HH-HMC-4

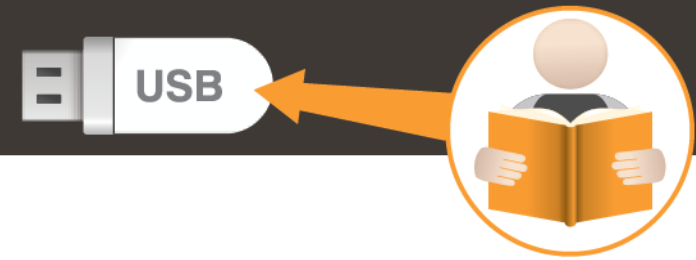

Mounting holes and orientation

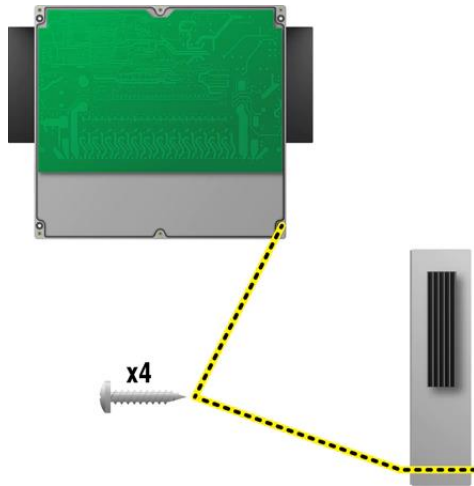

x4

Input power

- ◇ 120/230 VAC, 50/60 Hz

Control fuse [F5]

- ◇ 1 A, 250 VAC fast-acting glass

Variable stages [4: VAR1 to VAR4]

- ◇ 10 A at 120/230 VAC, general-purpose (resistive)
- ◇ 7 FLA at 120/230 VAC, PSC motor
1/2 HP at 120 VAC, 1 HP at 230 VAC, PSC motor

Variable stage fuses [4: F1 to F4]

- ◇ 15 A, 250 VAC ABC-type ceramic

Alarm relay

- ◇ 0.4 A at 125 VAC; 2 A at 30 VDC, resistive load
- ◇ 0.2 A at 125 VAC; 1 A at 30 VDC, inductive load

Incoming power and heat mats

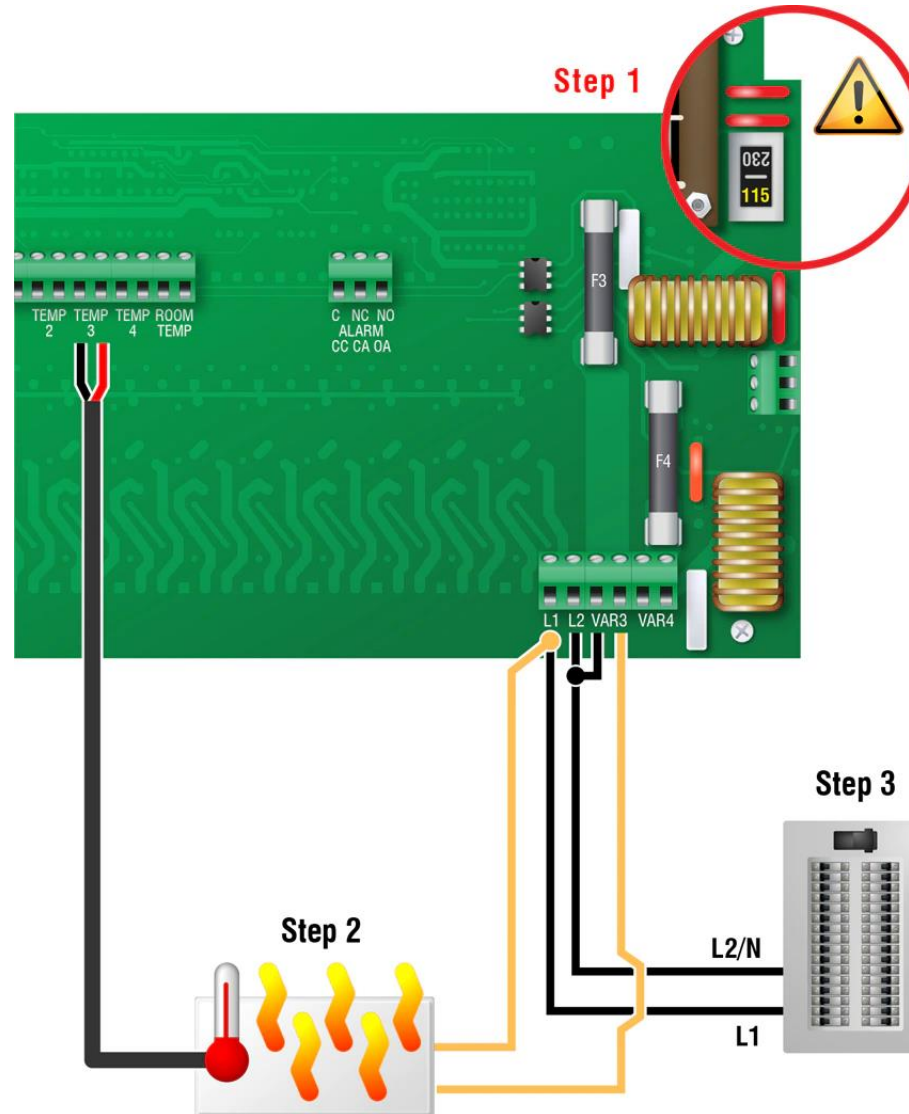

Normally open alarm system

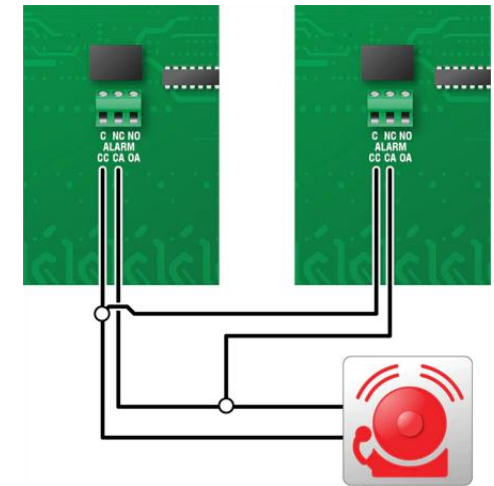

Normally closed alarm system

